



MODEL 73-801 SAFETY & INSTRUCTIONS MANUAL

GENERAL INFORMATION

Carefully inspect the unit for concealed damage that may have occurred during shipping and handling. If any damage is found, then you as the receiver must note and immediately contact the freight company. Make sure there are no dents in the housing, as they will prevent the filters from sliding into the units smoothly. **THIS IS YOUR RESPONSIBILITY.**

NOTE: Careful when unloading the unit off the skid, the unit is top heavy.

CAUTION: This device is powered by rotating electrical machinery!!! Careless or improper use may result in personal injury. Read the Safety Precautions and Warnings contained within **prior** to operating this machine.

READ AND SAVE THESE INSTRUCTIONS

SAFETY WARNINGS & CAUTIONS

FAILURE TO OBSERVE THE FOLLOWING PRECAUTIONS COULD RESULT IN SERIOUS INJURY, INCLUDING DEATH IN EXTREME CASES. SAVE THESE INSTRUCTIONS.

WARNING: (EXPLOSION HAZARD)

This unit contains parts which can arc or spark during normal operation. Do not use in areas contaminated by volatile or flammable materials as these sparks may ignite the contaminants and cause a dangerous explosion.

WARNING: (EXPLOSION HAZARD)

This machinery is not suitable for collection of combustible metal as listed in NFPA 484, which includes: **Aluminum, Titanium, Magnesium, Lithium, Niobium, and Zirconium.**

WARNING: (VOC'S & AIRBORNE MICROBES)

The filters used in this unit will remove solid particulate ONLY, and will not eliminate Volatile Organic Compounds (VOC's) or airborne microbes (bacteria, mold & viruses) that may be a health hazard. Failure to observe the presence of such fumes could cause serious illness or death.

CAUTION: (SHOCK HAZARD)

To insure continued protection against shock hazard, connect A.C. cord only to properly grounded outlets. Replace defective cords immediately. Don't expose to moisture or liquid as this could defeat the electrical insulation thus causing electrical shock.

CAUTION: (STRONG VACUUM)

Care must be taken to avoid personal injury by not allowing hose inlet to contact any body area such as eyes, ears, mouth, etc.

CAUTION: (LIFTING)

Improper lifting or handling of this unit could cause back injury. Follow the recommended method for lifting.

CAUTION: (AIR FLOW BLOCKAGE)

Since exhaust air leaves the end of this unit, caution should be observed not to position unit in such a way as to block the exhaust.

MISCELLANEOUS CAUTIONS:

1. Use of any attachment not recommended or sold by the air cleaner manufacturer may result in risk of fire, electric shock, or injury to persons.
2. To reduce the risk of damage to the electric plug or cord, disconnect by pulling plug rather than cord when removing power from the air cleaner.
3. Make sure cord and hose are located so they will not be stepped on, tripped over, or otherwise subjected to damage or stress.
4. An extension cord should not be used unless absolutely necessary. Use of improper extension cord could result in risk of fire and electric shock.

NOTE: If extension cord must be used, use only a grounded cord and follow these recommendations:

(25 ft. #12 AWG.)

(50 ft. #10 AWG.)

(100 ft. # 8 AWG.)

5. Do not disassemble the air cleaner. Take it to a qualified serviceman when service or repair is required. Incorrect reassembly may result in risk of electric shock or fire.
6. To reduce the risk of electric shock or bodily injury, unplug the air cleaner from outlet before attempting any maintenance or cleaning. Turning off the power switch will not eliminate this risk.

THEORY OF OPERATION

This unit is a portable air cleaner employing one thermally protected, high performance motor producing very high velocity air flow through the unit. Fine solid particulate material and smoke may be removed from the air by the filter media. An initial spark trap collects large particles before they reach the pre-filter. This trap further isolates the filters from sparks in the case of a welding operation. Upon leaving the trap, the air is passed through pre-filters. These pre-filters are designed to catch the larger particles leaving the trap. These relatively inexpensive pre-filters prevents the more expensive main filter from becoming quickly clogged. The pre-filters may be changed several times before the main filter needs to be changed.

All Factory furnished filters have a U.L. class II rating and using any filters other than those supplied for this unit is not recommended. Use of any product other than that recommended by the manufacturer will void the warranty.

The main (or final) filter may be selected from several grades available, depending upon the level of performance desired. All of these are high efficiency multi-flow filters which feature extended surface area for long life in high velocity filtration systems. See the Replacement Parts & Filters section toward the end of this manual for part numbers and filter efficiencies. Selection of the filter best suited for the job should be discussed with a dealer or a factory representative. A differential pressure gauge is an integral part of the unit. When the filters become clogged, the gauge will indicate an increase in differential pressure. At this point, the filters should be changed. Depending upon the application, the pre-filter can be changed several times before the main filter must be changed. Changing the pre-filters regularly can extend the useful life of the final filter up to 50%.

OPERATION

Your ACE Industrial Products machine is designed as a source capture device, i.e., it is intended to eliminate smoke and particulate at their point of origin. Keeping this in mind, the machine should be operated in the following manner:

Re-read the section on Safety Warnings & Cautions before proceeding any further.

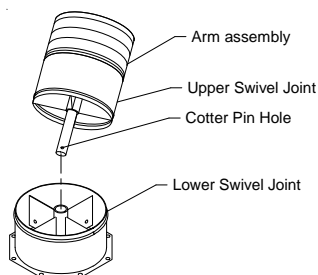

Fig. 1

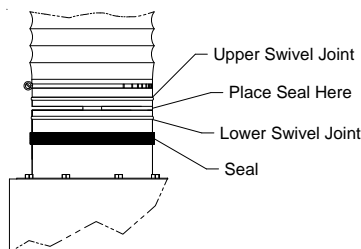

Fig. 2

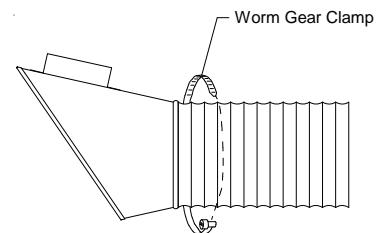

Fig. 3

1. Place the machine on a flat, level surface. Pick a location that will allow unrestricted flow of the exhaust air to the atmosphere.
2. For units with wheels or casters, lock the wheels or block the wheels.
3. Place the collection nozzle as close to the work as practical without interfering with the operator. Secure the nozzle if necessary.
4. Using the On/Off switch, turn the machine On. Should the motor not start, or should the machine make unusual noises, immediately turn the machine off and seek trained maintenance personnel. Do not continue to use the device.
5. Upon completion of the specific manufacturing or welding operation, turn the machine off. Continuous running of the air cleaner will reduce the life of the filters and increase utility costs.
6. When the differential pressure gage indicate that the filter(s) are clogged, turn the machine off and remove the power cord from its power source. Take out old filters and use the reverse process to replace the new filters. Reconnect the machine to its power source.

GENERAL MAINTENANCE

ONLY QUALIFIED SERVICE TECHNICIANS SHOULD MAKE REPAIRS TO THIS UNIT. DO NOT REPLACE THESE MOTORS WITH MOTORS OTHER THAN THOSE RECOMMENDED BY THE MANUFACTURER.

ASSEMBLY INSTRUCTIONS

1. Lift the unit from the pallet into vertical position.
2. Mount the hose assembly to the unit. Insert the shaft into the lower swivel joint. The flexible hose must be pulled back. Insert the cotter pin (supplied) by reaching through both swivel joints to the underside of the lower swivel joint (fig. 1)
3. Make sure that the seal is pulled up from the lower swivel joint to cover the gap between the lower and upper swivel joints (fig. 2).
4. Slip the end of the hose over the nozzle and secure it in place with the band clamp (supplied; fig 3).
5. Mount the handle to the side of the unit with four 5/16-18 hex bolts and washers (supplied; fig. 4).

FILTER LIST

<u>FILTER</u>	<u>DESCRIPTION</u>	<u>NUMBER</u>
Main Filter	20"x24" 95% Efficient Mini-Pleat	91-853
	20"x24" 65% EFFICIENT MINI-PLEAT	91-854
Pre-Filter (4" Required)	20"x24"x2" Pleated (10 SQ-FT Surface)	91-955
	20"x24"x4" Pleated (19.4 SQ-FT Surface)	91-956
	20"x24"x2" Aluminum Mesh	91-958
	Pre-Filter Wrap	91-962
Special Purpose	20"x24"x2" Charcoal Filter (Odor Control).....	91-937

REPLACEMENT PARTS LIST

(See page 4 exploded view)

<u>ITEM</u>	<u>DESCRIPTION</u>	<u>NUMBER</u>
1	Motor	65024
2	Power Switch.....	65026
3	Vacuum Gauge	65027
4	Arm Assembly (includes Hose & Upper Swivel)	65028
5	Replacement Hose (Hose only).....	65029
6	Swivel Caster (Pkg. of 1)	65030
7	Fixed Caster (Pkg. of 1)	65031
8	V-Belt (Not Shown).....	65056
9	Blower Assembly	65035
10	AC Power Cord (Not Shown).....	65055
11	Handle	65061

OPTIONAL EQUIPMENT

<u>DESCRIPTION</u>	<u>PRODUCT NUMBER</u>
Dual Arm.....	99-799
"POWER-MATIC" Controller	99-800
Heavy Duty TDS Hose (Hose Only).....	65062

WIRING DIAGRAM

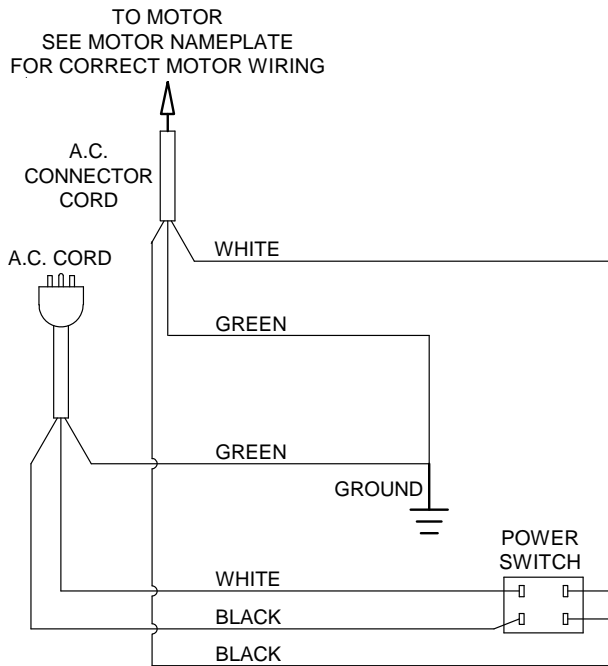

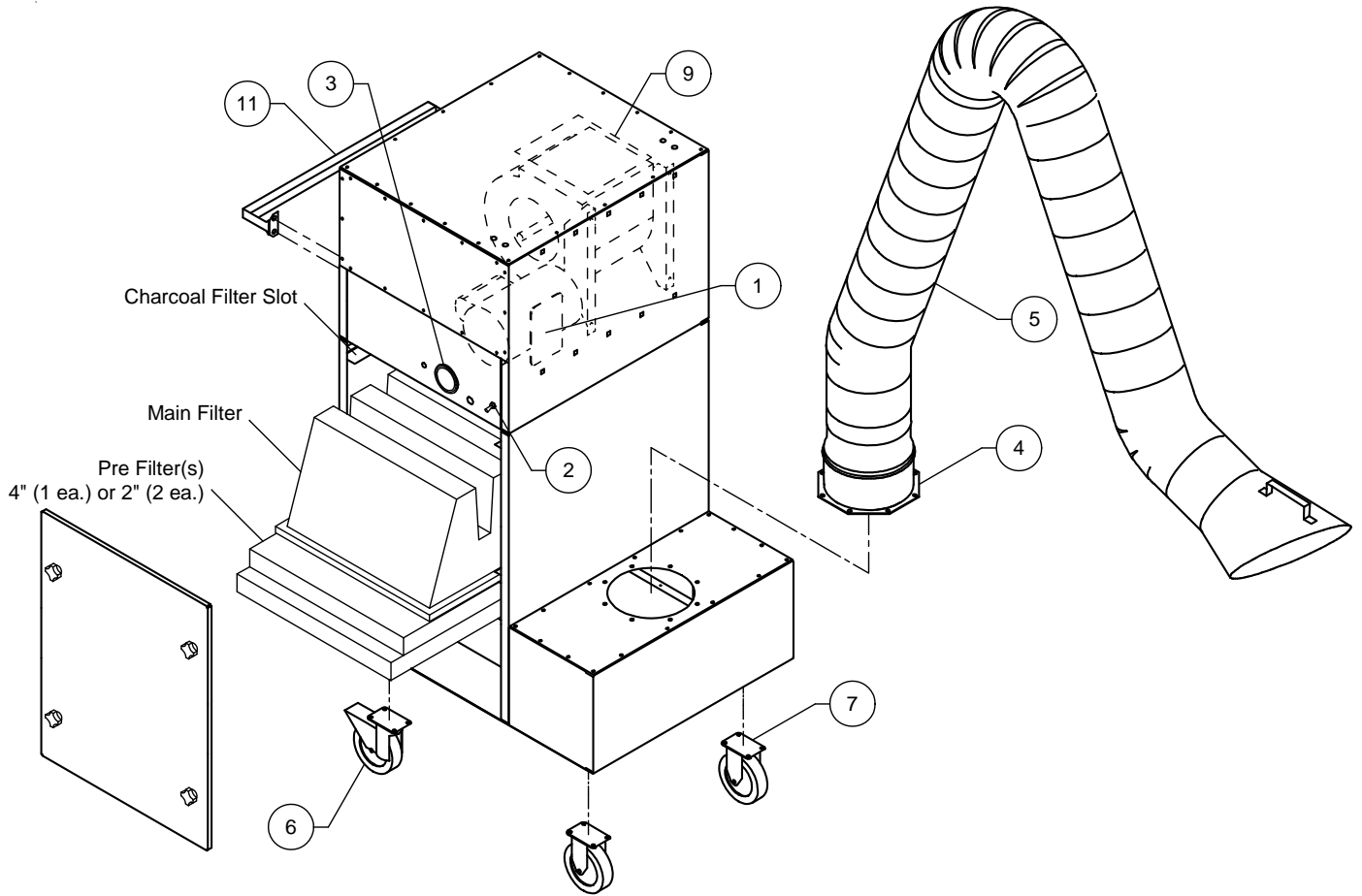

ACE INDUSTRIAL PRODUCTS

A Division Of:

ASSOCIATED EQUIPMENT CORPORATION

5043 Farlin Avenue St. Louis, MO. 63115

TEL: (314)385-5178 FAX: (314)385-3254

www.aceindustrialproducts.com