



# ACE INDUSTRIAL PRODUCTS PORTABLE FUME EXTRACTOR MODEL 73-250

## SAFETY & INSTRUCTION MANUAL

**CAUTION:** This device is powered by rotating electrical machinery!! Careless or improper use may result in personal injury. Read the Safety Precautions and Warnings contained within prior to operating this machine.

### READ AND SAVE THESE INSTRUCTIONS.

#### SAFETY WARNINGS & CAUTIONS

FAILURE TO OBSERVE THE FOLLOWING PRECAUTIONS COULD RESULT IN SERIOUS INJURY, INCLUDING DEATH IN EXTREME CASES. SAVE THESE INSTRUCTIONS.

#### **WARNING: (EXPLOSION HAZARD)**

This unit contains universal motors which spark during normal operation. Do not use in areas contaminated by volatile or flammable materials as these sparks may ignite the contaminates and cause a dangerous explosion.

#### **WARNING: (VOC's & Airborne Microbes)**

The filters used in this unit will remove solid particulate ONLY and will not eliminate Volatile Organic Compounds (VOC's) or airborne microbes (bacteria, mold & viruses) that may be a health hazard. Failure to observe the presence of such fumes could cause serious illness or death.

#### **CAUTION: (SHOCK HAZARD)**

To insure continued protection against shock hazard, connect A.C. cord only to properly grounded outlets. Replace defective cords immediately. Don't expose to moisture or liquid as this could defeat the electrical insulation thus causing electrical shock.

#### **CAUTION: (STRONG VACUUM)**

Care must be taken to avoid personal injury by not allowing hose inlet to contact any body area such as eyes, ears, mouth, etc.

#### **CAUTION: (LIFTING)**

This unit weighs more than 40 lbs. with filters, improper lifting or handling of this unit could cause back injury.

#### **CAUTION: (AIR FLOW BLOCKAGE)**

Since exhaust air leaves the bottom of this unit, caution should be observed not to set unit down in such a way as to block the exhaust.

#### **MISCELLANEOUS CAUTIONS:**

1. Use of any attachment not recommended or sold by the air cleaner manufacturer may result in risk of fire, electric shock, or injury to persons.
2. To reduce the risk of damage to the electric plug or cord, disconnect by pulling plug rather than cord when removing power from the air cleaner.
3. Make sure cord and hose are located so they will not be stepped on, tripped over, or otherwise subjected to damage or stress.
4. An extension cord should not be used unless absolutely necessary. Use of improper extension cord could result in risk of fire and electric shock. If extension cord must be used, use only a grounded cord and follow these recommendations:  

25 ft.	#14 AWG
50 ft.	#12 AWG
100 ft.	#10 AWG
5. Do not disassemble the air cleaner. Take it to a qualified serviceman when service or repair is required. Incorrect reassembly may result in risk of electric shock or fire.
6. To reduce the risk of electric shock or bodily injury, unplug the air cleaner from outlet before attempting any maintenance or cleaning. Turning off the power switch will not eliminate this risk.

## THEORY OF OPERATION

This unit is a lightweight, portable air cleaner employing two thermally protected, high performance, flow through vacuum motors producing very high velocity air flow through the unit. By utilizing a large (2 ½") inlet plus a variety of collecting nozzles and fittings, fine solid particulate material and smoke may be removed from the air by the filter media.

An initial spark trap collects large particles before they reach the filter. An easy to empty tray is attached to the front cover to enable the removal of the large particles collected by the spark trap without removing the filter. This trap further isolates the filter from sparks in the case of a welding operation.

A "clogged" filter light, actuated by a differential pressure switch is an integral part of the unit. When the filters become clogged, the light will illuminate. At this point, the filter should be changed or cleaned.

## GENERAL MAINTENANCE

ONLY QUALIFIED SERVICE TECHNICIANS SHOULD MAKE REPAIRS TO THIS UNIT.

DO NOT REPLACE THESE MOTORS WITH MOTORS OTHER THAN THOSE RECOMMENDED BY THE MANUFACTURER

## UNPACKING

Carefully inspect the unit for concealed damage that may have occurred during shipping and handling. If any damage is found, immediately contact the freight company. Make sure that there are no dents in the housing, as they might prevent the filter from sliding into the unit smoothly. If there is no evidence of damage, remove the end cover by releasing the two rubber latches. Removal of the front cover will allow inspection of the inside of the unit.

After unpacking the machine, check to see that the following parts and accessories are present:

- (1) 10' Flexible Hose
- (1) Flexible Metal Hose/Magnetic Base Component Parts. (See Figure 2 for Individual Parts Included)
- (1) Slot Nozzle
- (1) Cartridge Filter

## INSTALLATION (See Figure 1)

1. Insert the filter, gasket first, into the unit. Then place washer over the threaded rod and tighten the wing-nut down so that the filter is sealed and will not rotate.
2. Replace the front cover/spark trap assembly and re-latch the cover using the rubber latches.
3. Connect the unit to the power source and test the operation of the unit by turning it ON with the On/Off switch. Should the motors not start, or should the machine make unusual noises, immediately turn the machine off and seek trained maintenance personnel. Once the test is complete, turn the unit back OFF.
4. Attach the hose to the inlet.
5. Assemble the flexible metal hose and nozzle per Figure 2.
6. Connect the hose/nozzle combination assembled in Step 5 above to the machine with the 10' flexible hose and the supplied coupling.

This completes the basic assembly of your unit. Depending upon the accessories ordered and the logistics of the work place, the installation configuration may vary.

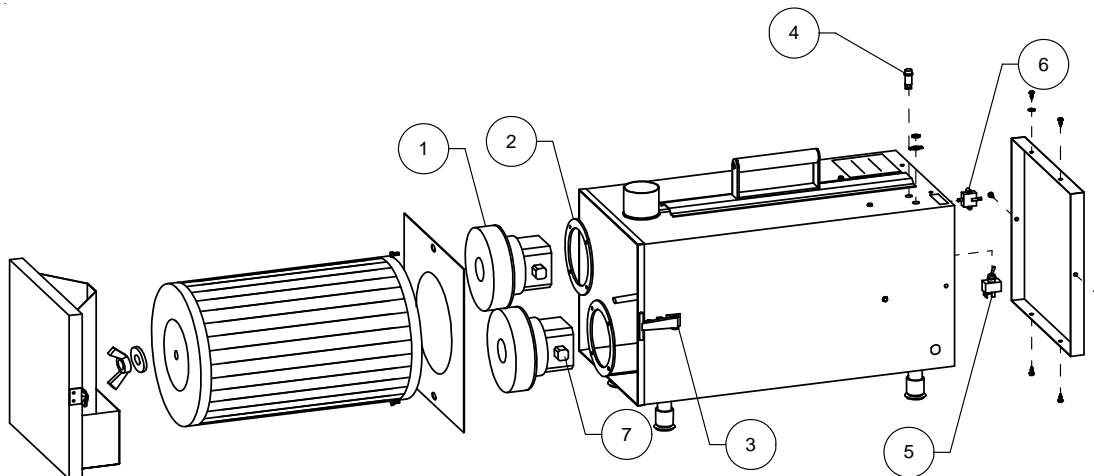

Figure 1

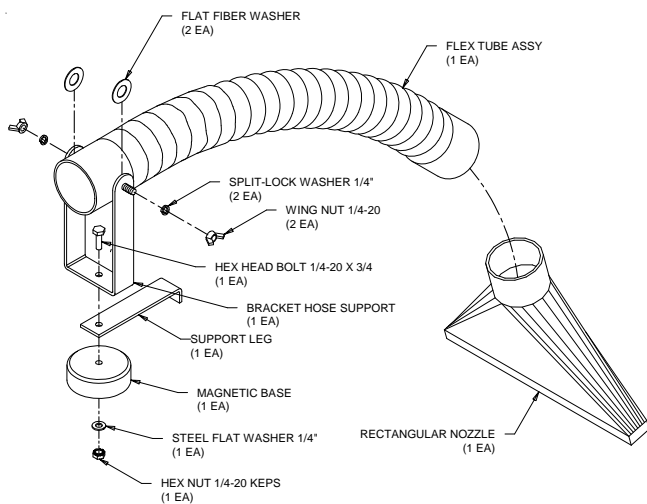

Figure 2

**OPERATION**

Your Ace Industrial Products machine is designed as a source capture device, i.e., it is intended to eliminate smoke and particulate at their point of origin. Keeping this in mind, the machine should be operated in the following manner:

Re-read the section on Safety Warnings & Cautions before proceeding any further.

1. Place the machine on a flat, level surface. Pick a location that will allow unrestricted flow of the exhaust air to the atmosphere.
2. For units with wheels or casters, lock the wheels or block the wheels.
3. Place the collection nozzle as close to the work as practical without interfering with the operator. Secure the nozzle if necessary.
4. Using the ON/OFF switch, turn the machine on. Should the motor not start, or should the machine make unusual noises, immediately turn the machine off and seek a trained maintenance personnel. Do not continue to use the unit.
5. Upon completion of the specific manufacturing or welding operation, turn the machine off. Continuous running of the unit will reduce the life of the filter and the motor brushes as well as increase utility cost.
6. When the "clogged" filter light indicates that the filter is clogged, turn the machine off and remove power cord from its power source.

See the section on installation and use the reverse process to remove the dirty filters. Re-install the new filter and reconnect the machine to its power source.

**MAINTENANCE & REPLACEMENT PARTS:**

**FILTER:**

As previously stated in the "Theory of Operation" section of this manual, the "clogged" filter indicator light will light whenever the differential pressure across the filter indicates that the filter is clogged. When opening the unit, there are no vacuum hoses to disconnect since the pressure sensing is accomplished by measuring at the inlet and inside the suction chamber. The differential pressure trip point is preset and is not field adjustable.

When the filter gets dirty, it needs to be replaced with a new one or the filter can be cleaned. To clean, take the filter out of the unit and hold the filter 2 to 3 inches above a concrete floor and drop the filter and rotate it until most of the dirt falls out of the filter or the filter can be vacuumed with a portable air vac (If needed, order 80-201MD). To re-assemble, use reverse process to remove filter and sweep up dirt that is on the floor.

**REPLACEMENT FILTER**

Cartridge Filter ..... 65250

**MAINTENANCE:**

**WARNING:** MAINTENANCE ON THIS UNIT SHOULD BE PERFORMED ONLY BY QUALIFIED, TRAINED TECHNICIANS.

1. Motor Brushes- Motor brushes are available from the company by ordering PART NUMBER 65007. The use of high performance ball sleeve motors provide about 500 hours of brush operation (depending upon filter condition). Brushes should be periodically checked after 500 hours use and if worn, replace as a matter of preventative maintenance.
2. Vacuum Motors- Motors are available from the factory by ordering PART NUMBER 65001. These motor are thermally protected by an automatic reset thermal circuit breaker and will shut down if they are overheated due to lack of air flow or locked rotor condition.

**DO NOT REPLACE THESE MOTORS WITH A MOTOR THAT DOES NOT HAVE A THERMAL OVERLOAD!**

**REPAIR PARTS**

- (1) Motor w/screws ..... 65001
- (2) Motor Gasket..... 65002
- (3) Rubber Latch..... 65003
- (4) Clogged Filter Indicator Light ..... 65004
- (5) ON/OFF Toggle Switch ..... 65005
- (6) Differential Pressure Switch ..... 65006
- (7) Motor Brushes ..... 65077

**ACCESSORIES**

The following accessories and attachments are available from the factory or from your Ace dealer.

- Flex Tube ..... 65012
- Magnetic Base ..... 65014
- 10' Extension Hose & Coupling ..... 65017
- Slot Nozzle..... 65019
- 20" Slot Nozzle..... 65036
- "T" Adapter..... 65040
- Reducer, 1-1/4" (Smoke Extracting Gun)..... 65041
- Reducer, 1-1/2" (Smoke Extracting Gun)..... 65043
- Power-Matic Inductive Switch ..... 99-800

**SCHEMATIC WIRING DIAGRAM**

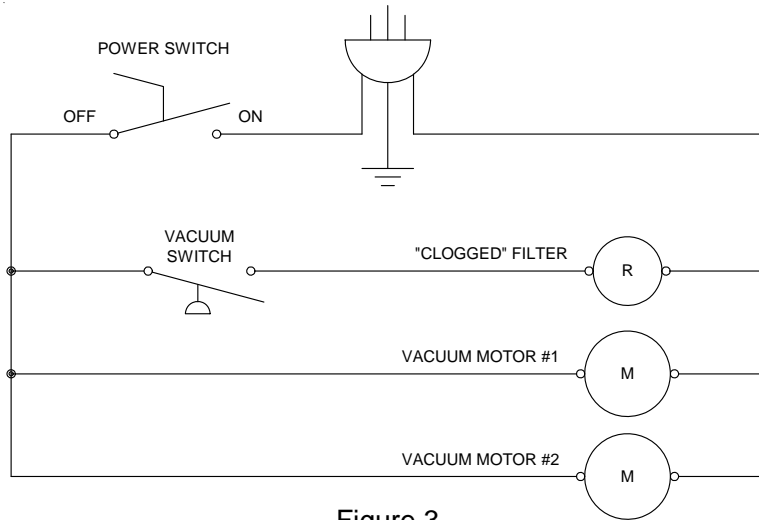

Figure 3

**ACE INDUSTRIAL PRODUCTS**  
**By Associated Equipment Corporation**  
 5043 Farlin Avenue  
 St. Louis, MO 63115  
 Tel. (314) 385-5178 Fax. (314) 385-3254  
[www.aceindustrialproducts.com](http://www.aceindustrialproducts.com)